



PRODUCT SPECIFICATION

2. Revision History

Date	Rev. No	Page	Summary
2022-10-08	Rev1.0	All	1'st issued

2. Scope

This document is the specification of 27 Inch Flat MONITOR for application of Multi-sync. This monitor is a High quality FHD TFT-LCD display solution for industrial display device having RoHS conformity.

3. Features

- Supports up to 1920x1080, 60Hz
- On Screen Display (OSD)
- 8-bit(6bit+FRC) Color depch,display 16.7M colors
- HDMI DP VGA for Panel interface

4. Electrical Specification

4.1 Input Power

4.1.1 Input power is required as

Voltage : Monitor - DC IN 12[V] / 5.00[A]
LED - DC 12[V] / 4.00[A]

Consumption: Monitor - 50[W]Max
LED - 33 [W] Max

4.2 Input Signal

- 4.2.1 DP Port input: V1.2
- HDMI Port input: V2.0
- VGA Port input



4.3 Mode & Timing

4.3.1 Supply Video Timing Chart (VESA)

■ : Native Mode

Resolution	Refresh Rate	H Frequency	Main Frequency	Remark
640 x 480	60 Hz	31.5 kHz	25.175 MHz	n/a
800 x 600	60 Hz	37.9 kHz	40.000 MHz	VESA
1024 x 768	60 Hz	48.4 kHz	65.000 MHz	VESA
1280 x 720	60 Hz	44.697Khz	74.375Mhz	VESA
1360 x 768	60Hz	48.0Khz	86.00 Mhz	VESA
1440 x 900	60Hz	55.9KHz	106.50Mhz	VESA
1600 x 900	60 Hz	55.99 kHz	118.25 MHz	VESA
1680 x 1050	60Hz	65.3Khz	146.250Mhz	VESA
1920 x 1080	60 Hz	67.3Khz	148.00Mhz	VESA

5. LCD Panel Specifications

5.1 Screen Specification

Item	Specification	Unit	Remark	Note
Display Area	597.89(H) x 336.31 (V)	mm		
Driver Element	a-Si TFT active matrix	Dot		
Display Colors	16.7M (8bit)	Color		
Number of Pixel	1920 x 1080	Pixel		
Pixel Arrangement	RGB Vertical Stripe			
Pixel Pitch	0.3114(H) x 0.3114 (W)	mm		
Colour Gamut	92% NTSC			
Viewing Angle	89/89/89/89 (U/D/L/R)	Degrees	CR≥10	①
Weight	TBD	g	Max.	
Contrast Ratio	Typ = 1000:1		Center of Screen	② ④ ⑤
Response Time	On/Off = 14 ms		Typ.	③
White Luminance	TYP = 550cd/m ²	cd/m ²	Center of Screen	④ ⑤
Brightness Uniformity	Min = 75 %	%		⑥

© Vendor Name: AUO

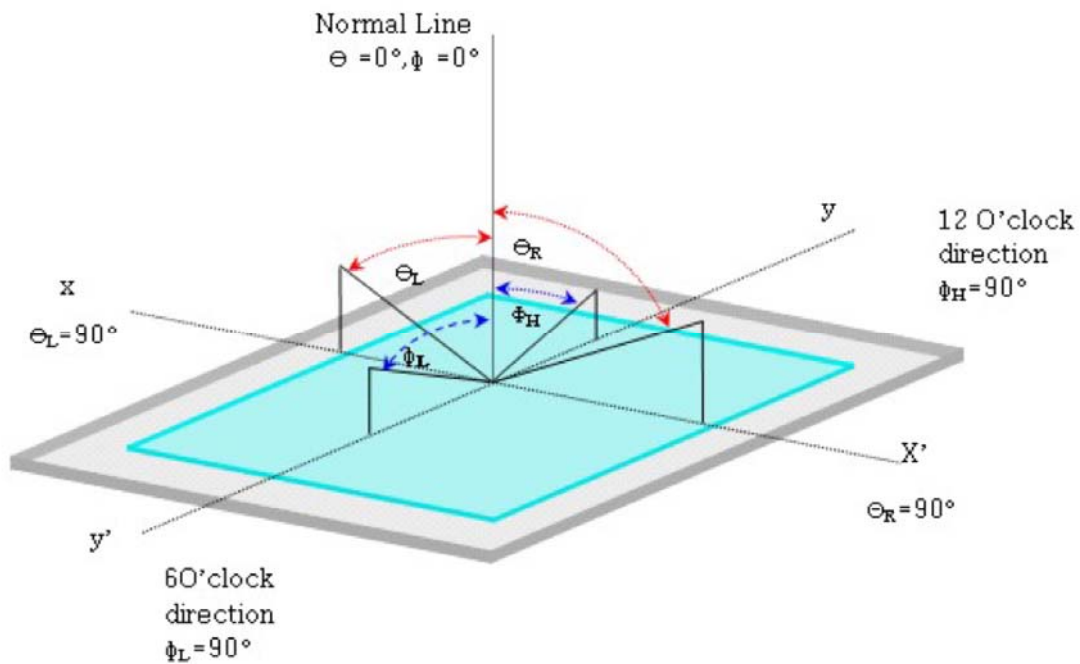

① Viewing Angle

Hor.	θ_L	CR ≥ 10 (at center of screen)	Right	89	Degree
	θ_R		Left	89	
Ver.	θ_H		Up	89	
	θ_L		Down	89	

② Contrast Ratio (CR): Ratio of gray max. (G max.), gray min. (G min.) at the center point of panel.

$$CR = \frac{\text{Luminance of all pixels White}}{\text{Luminance of all pixels black}}$$

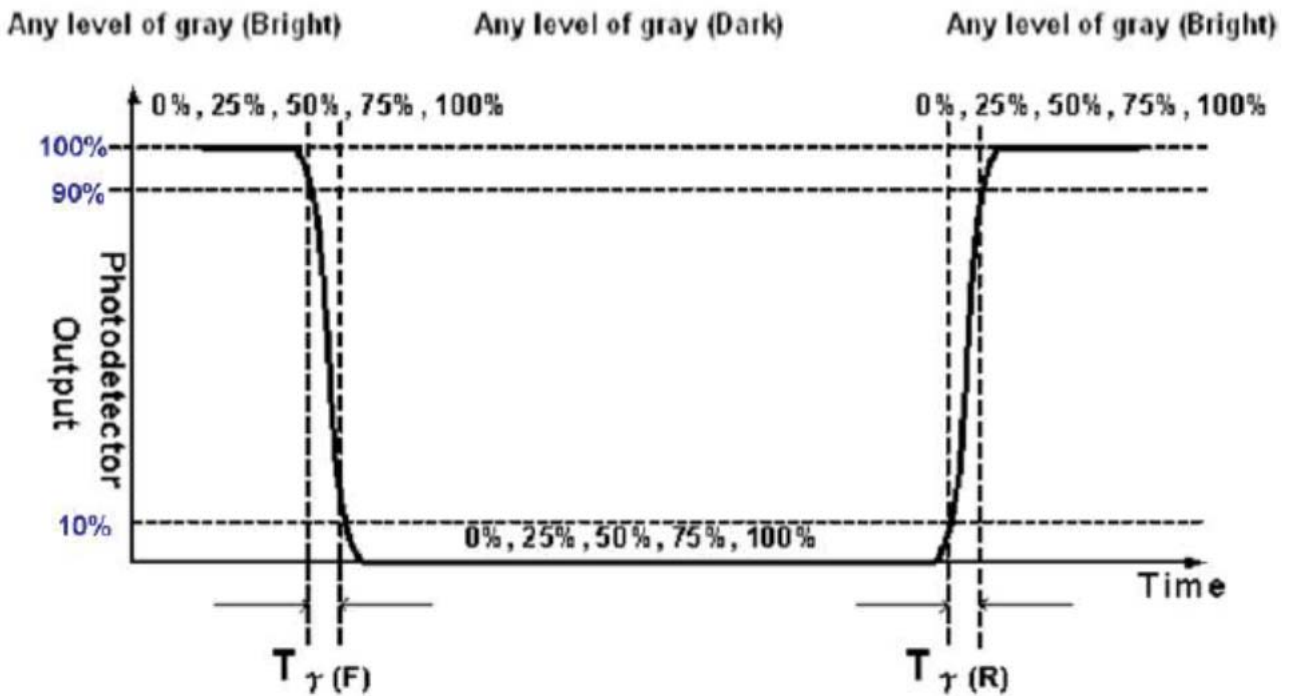

③ Response Time: Sum of TR, TF

④ Luminance of White (Center of Screen)

⑤ Optical characteristics measurement

5.2 Test Equipment Setup

After stabilizing and leaving the panel alone at a given temperature for 30 min, the measurement should be executed. Measurement should be executed in a stable, windless, and dark room 30min after lighting the back-light. This should be measured in the center of screen.

A single lamp current: 6.5[mA] Environment condition: $T_a = 25 \pm 2 [^{\circ}\text{C}]$

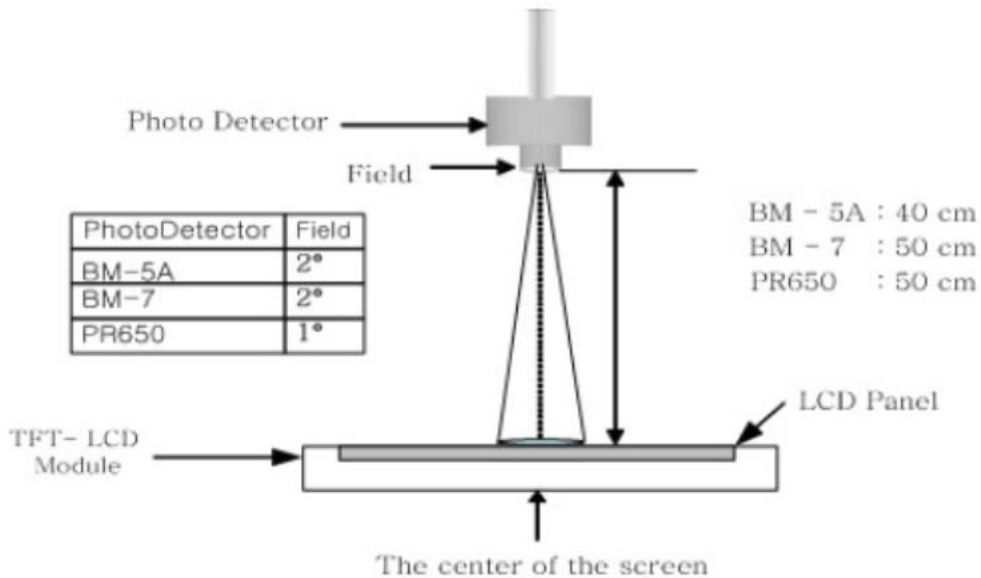

⑥ Brightness uniformity (9 points)

$$B_{uni} = 100 \cdot (B_{max} - B_{min}) / B_{max}$$

B_{max} : Maximum brightness, B_{min} : Minimum brightness

Definition of test point

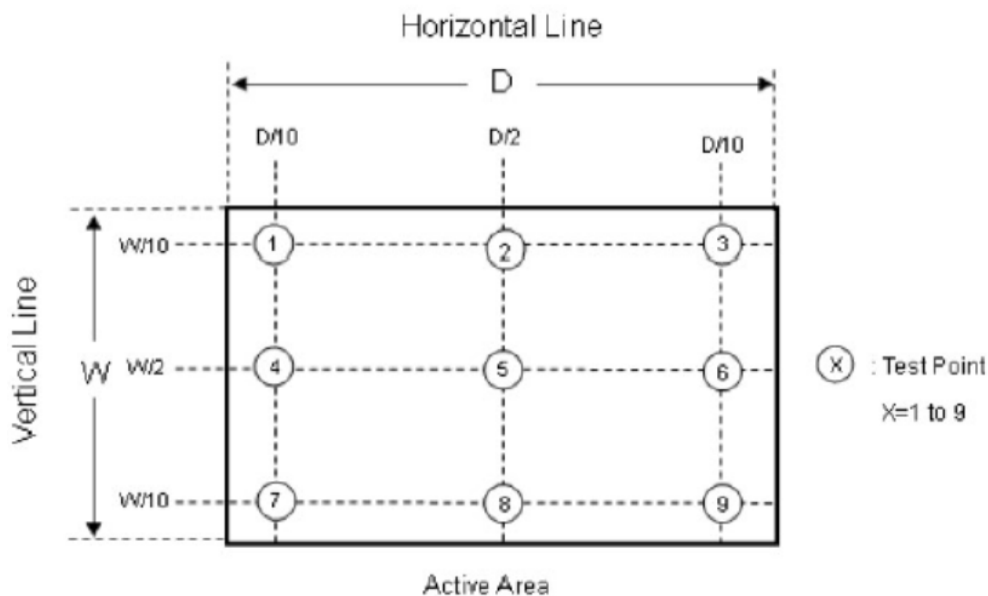

5.3. Back Light Unit

The Back-light system is an edge-lighting type with LEDs (Light Emitting Diode)

ITEM	MIN	TYP	MAX
INPUT VOLTAGE	-	12V	-
INPUT CURRENT	-	3A	-
OUTPUT VOLTAGE	-		51V
OUTPUT CURRENT (CH max)	-	700mA	-
OUTPUT CURRENT (CH min)	-		
OUTPUT POWER	-		43.4W
BLU ON SIGNAL	3.3V		5V
BLU OFF SIGNAL	0V		0.5V
A-DIM SIGNAL	1.4V		5.0V

5.4 CIE Coordinates (Color Chromaticity)

Item	Color chromaticity (CIE 1931)	
	X(Typ.)	Y(Typ.)
White	0.313 ± 0.03	0.329 ± 0.03

5.5 Absolute Maximum Rating

5.5.1 Absolute rating of environment

ITEM	Symbol	Min	Max	Unit	Note
Storage temperature	T _{STG}	-20	60	°C	(1)
Operating temperature (Surface of Glass temperature)	T _{OPR}	0	40	°C	(1)
Shock (non - operation)	S _{NOP}	-	30	G	(2),(4)
Vibration (non - operating)	V _{NOP}	-	1	G	(3),(4)

***Note**

- (1) Temperature and relative humidity range are shown in the figure below, 90% RH Max.(40 °C ≥ Ta)
- (2) 2ms, half sine wave, one time for ±X, ±Y, ±Z axis.
- (3) 10-300Hz, Sweep rate 10min, 30min for X, Y, Z axis.
- (4) At testing Vibration and Shock, the fixture in holding the Module to be tested have to be hard and rigid enough so that the Module would not be twisted or bent by the fixture.

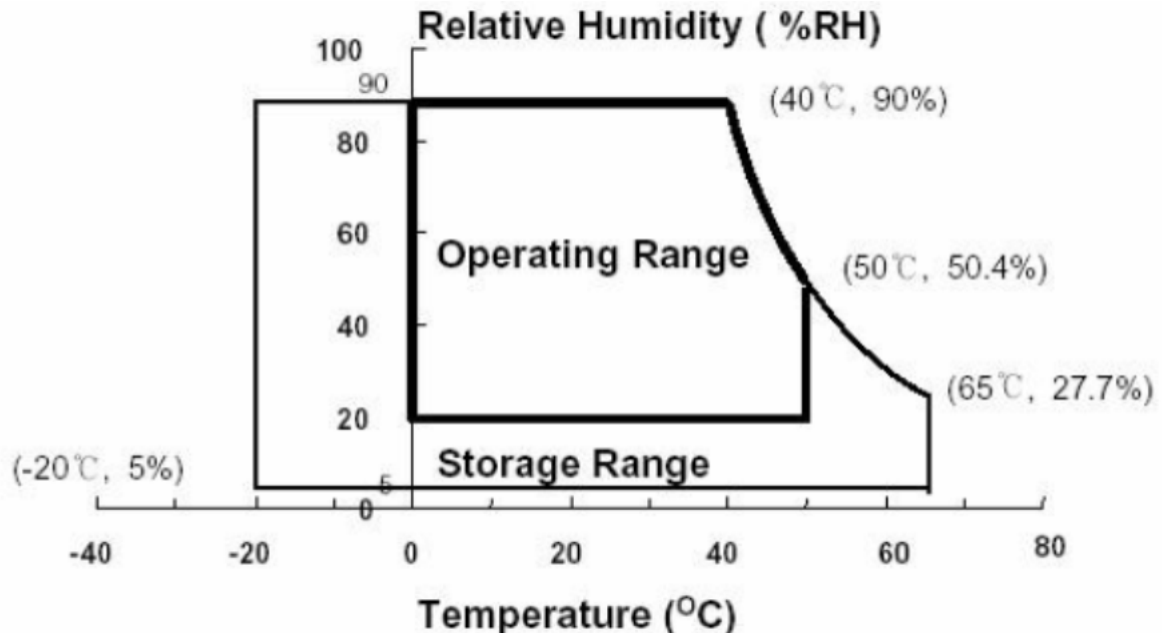

6. Visual Specification

6.1 Standard Mode & Display Size

Item	Specification	Note
Standard Mode	1920 * 1080 @ 60 [Hz]Resolution	Recommend Mode
Display Size	579.89(H) x 336.31(V)	Panel Active Visual Size

6.2 Standard Condition

Item	Specification	Note
Warm up Time	30 minutes after lighting	
Panel Face	None	
AC / DC Adapter	12V DC IN	

6.3 Screen image Stabilizing Time

Item	Specification	Note
Video Display Time	After turning power switch on, within 15 seconds	
Display Stability time	After turning power switch on, within 30 seconds	
AC input Voltage Stability	All specifications should be within 10% at 100~240V.	
Environments stability	All specifications should be within 2% at the operating temperature	

Note) All kinds of specification should be satisfied after 30 minutes from turning power switch on.

6.4 H & V Centering : 1920 × 1080, 60Hz

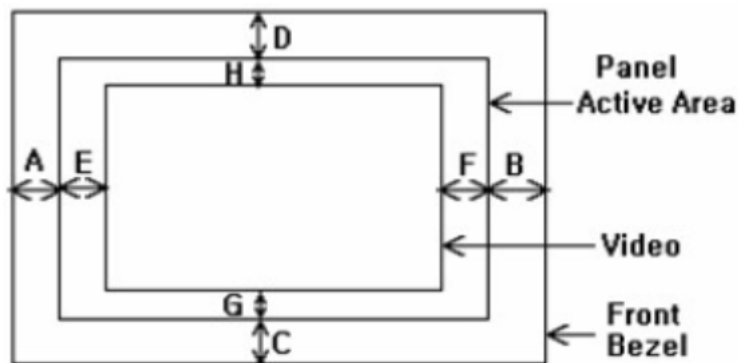

$$|A-B| \text{ and } |C-D| \leq 1.0[\text{mm}], |E-F| \text{ and } |G-H| \leq 1.0[\text{mm}]$$

6.5 Focus

Focus shall be inspected by using both normal H-character pattern and reversed one, after adjusting the brightness to 80 steps and contrast to 80 steps by the OSD. The intersection between black and white character s should be clearly visible at all the points on the screen, and the focus performance shall be evaluated from a viewing distance of 50cm

6.6 Color Spread

The color must not spread on the panel, especially on the 4 side that panel and bezel contact each other.

6.7 Noise, Jitter, Color lack, Screen shrink, and etc.

During the operations, there should not be a noise, jitter, color lack, screen shrink, etc. on the screen.

6.8 Residual Image

After 10 hours' aging at the same pattern, video pattern will be changed for the residual image inspection. The image sticking should disappear after 2 hours have passed.

6.9 Crosstalk

Crosstalk shall be investigated visually by a white box pattern. Any cross-talk effect must not be seen on the white area.

7. A/D Board

This board is main controller board and has following functions.

- Scaling: input signal to fit Panel's resolution.
- Converter Power control.
- DC to DC conversion to supply various power to each circuit

7.1 A/D Board Connectors



7.2 A/D Board connection

Symbol	Description	Parts Number	Manufacture
1	DC IN 12V	-	
2	DP INPUT	-	
3	HDMI INPUT	-	
4	VGA INPUT		
9	LVDS		
10	OSD		

7.3 OSD Key

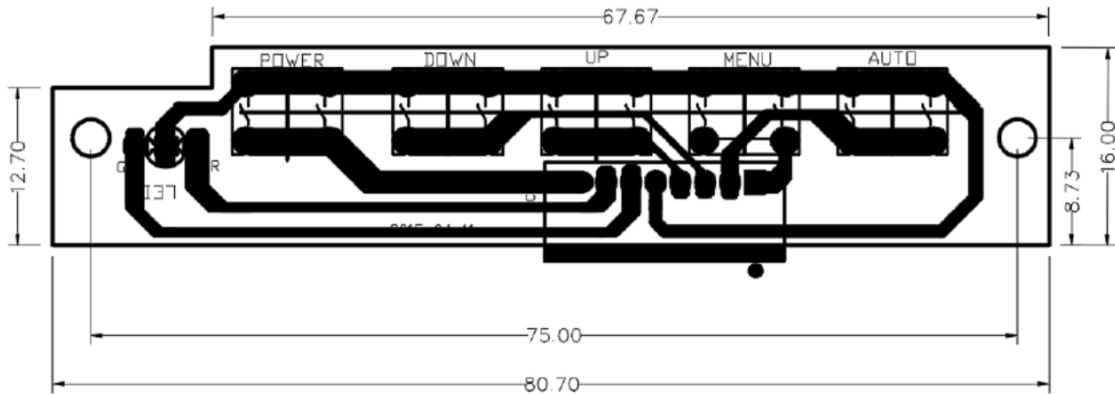

- **MENU Key** : Use this key into the menu OSD.
- **AUTO key** : To select the items in the OSD panel.
- **UP/DOWN key** : To adjust the items in the menu OSD
- **Power Indicator** : It shows monitor is on when green

7.4 OSD Menu Structure

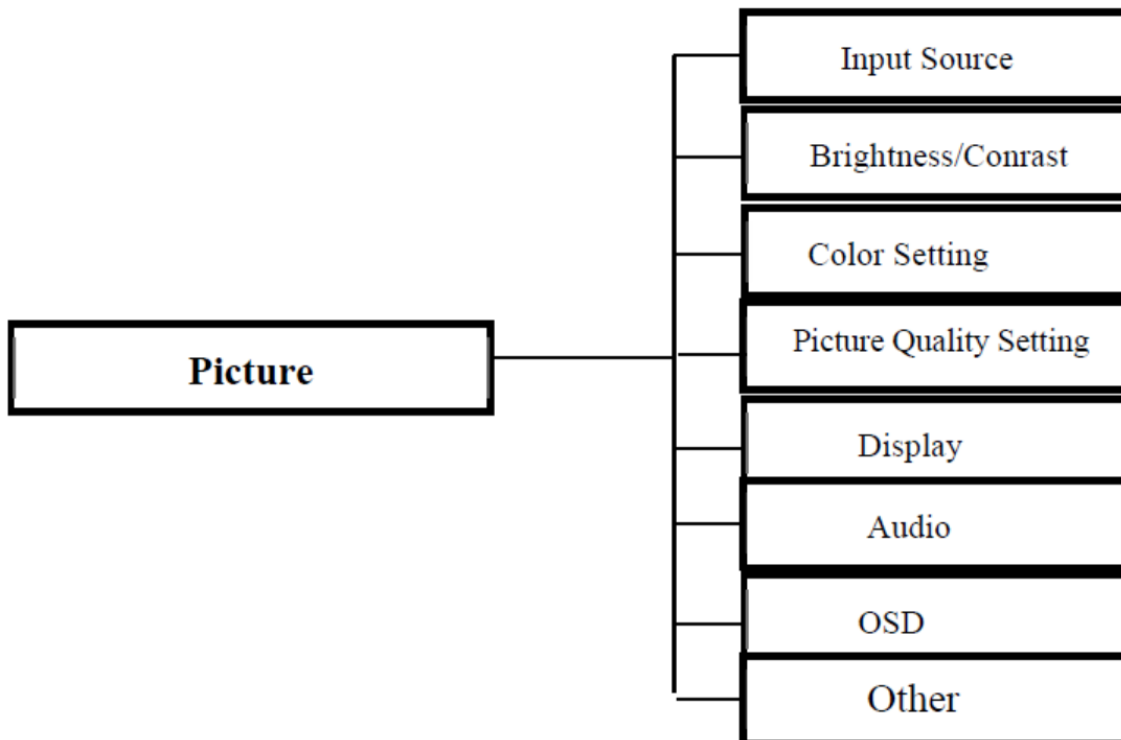

8. Touch Controller

8.1 Dimension

Parameter	Value	Remark
Width	100 mm	
Height	30 mm	

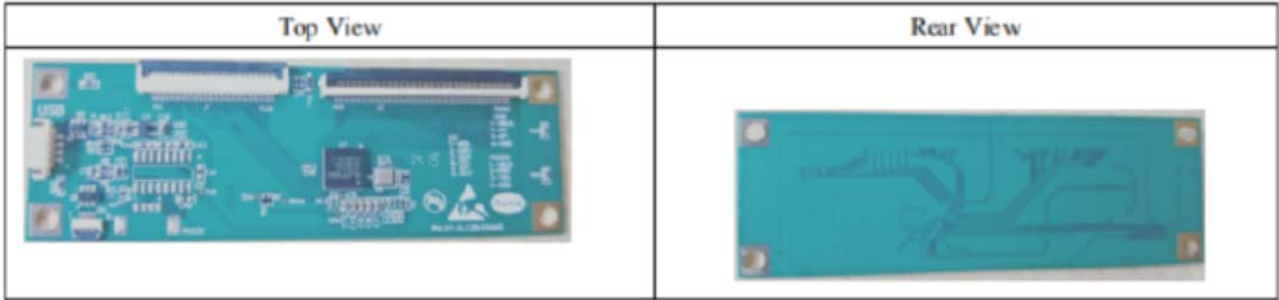

8.2 Touch Controller IC - ILI2312

8.3 Touch CONNECTOR - USB



4-Pin, Pin Pitch=1.25mm, Part Number: MOLEX/53261-0419										
Pin	1	2	3	4						
Name	USB5V	DN	DP	GNDIN						

